

■Features

- High Luminous Super Flux Output
- Superior Weather-resistance
- UV Resistant Epoxy
- Long Lifetime Operation
- Water Clear Type

■Applications

- General Purpose Indicators
- Small Area Illuminations
- Back Lighting
- Other Lighting

■Outline Dimension

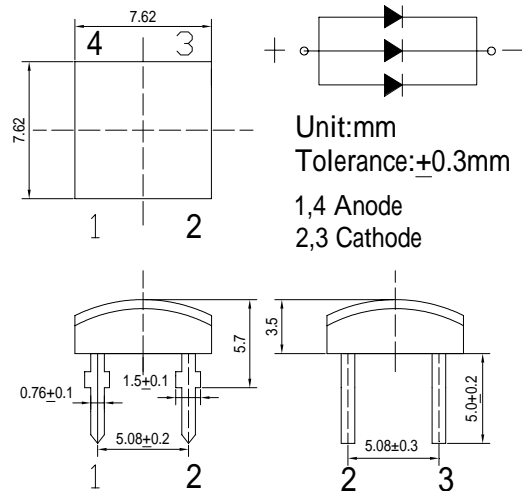

■Absolute Maximum Rating

(Ta=25)

Item	Symbol	Value	Unit
DC Forward Current	I_F	150	mA
Pulse Forward Current*	I_{FP}	360	mA
Reverse Voltage	V_R	5	V
Power Dissipation	P_D	540	mW
Operating Temperature	T_{opr}	-30 ~ +85	
Storage Temperature	T_{stg}	-40 ~ +100	
Lead Soldering Temperature	T_{sol}	260 / 5sec	-

■Directivity

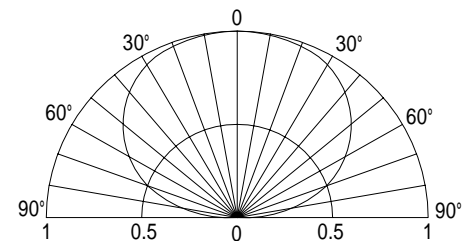

*Pulse width Max.10ms , Duty ratio max 1/10

Electrical -Optical Characteristics

(Ta=25)

Item	Symbol	Condition	Min.	Typ.	Max.	Unit
DC Forward Voltage	V_F	$I_F=90mA$	2.9	3.1	3.6	V
DC Reverse Current	I_R	$V_R=5V$	-	-	10	μA
Luminous Flux*	ν	$I_F=90mA$	-	30	-	lm
Color Temperature	CCT	$I_F=90mA$	-	6500	-	K
Chromaticity Coordinates*	x	$I_F=90mA$	-	0.31	-	
	y	$I_F=90mA$	-	0.33	-	
50% Power Angle	$2\theta_{1/2}$	$I_F=90mA$	-	140	-	deg

*1 Tolerance of chromaticity coordinates is ±10%

*2 Tolerance of luminous intensity is ±15%