

**■Features**

- High Radiant Power LEDs
- 5mm Standard Directivity
- Superior Weather-resistance
- UV Resistant Epoxy
- Water Clear Type

**■Applications**

- IrDA
- Encoder
- Data Communication
- IR camera

**■Outline Dimension**

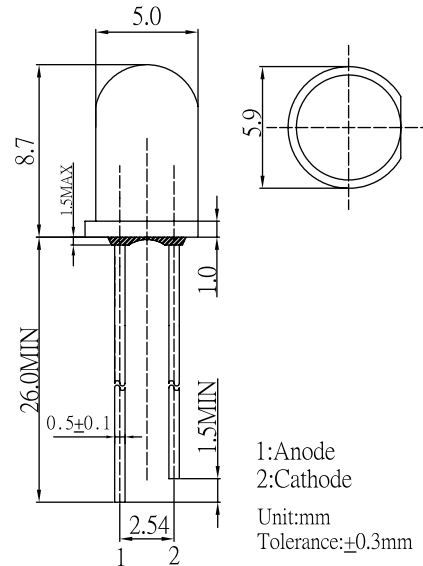

**■Absolute Maximum Rating**

(Ta=25°C)

Item	Symbol	Value	Unit
DC Forward Current	I <sub>F</sub>	70	mA
Pulse Forward Current*	I <sub>FP</sub>	700	mA
Reverse Voltage	V <sub>R</sub>	5	V
Power Dissipation	P <sub>D</sub>	126	mW
Operating Temperature	T <sub>opr</sub>	-30 ~ +85	°C
Storage Temperature	T <sub>stg</sub>	-40 ~ +100	°C
Lead Soldering Temperature	T <sub>sol</sub>	260°C / 5sec	-

\*Pulse width Max.10ms Duty ratio max 1/10

**■Directivity**

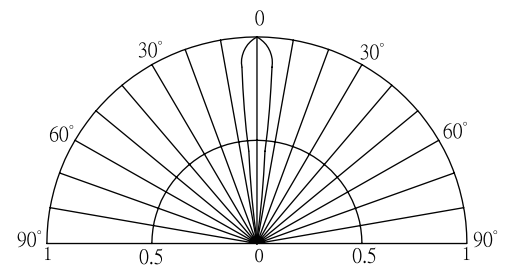

**■Electrical -Optical Characteristics**

(Ta=25°C)

Item	Symbol	Condition	Min.	Typ.	Max.	Unit
DC Forward Voltage	V <sub>F</sub>	I <sub>F</sub> =50mA	-	1.6	1.8	V
DC Reverse Current	I <sub>R</sub>	V <sub>R</sub> =5V	-	-	10	μA
Peak Wavelength	λ <sub>p</sub>	I <sub>F</sub> =50mA	-	850	-	nm
Radiant Intensity	I <sub>e</sub>	I <sub>F</sub> =50mA	30	45	-	mW/Sr
50% Power Angle	2θ <sub>1/2</sub>	I <sub>F</sub> =50mA	-	15	-	deg

\*1 Tolerance of Peak wavelength is ±1nm

\*2 Tolerance of luminous intensity is ±15%

**AlGaAs LED**

TYPICAL ELECTRICAL/OPTICAL CHARACTERISTIC CURVES

