

# SPECIFICATION SHEET

**Part Number:LP-50AFWS2812B**

**Description:**

- 4.8\*5.8MM
- Lens Color: Water Clear
- Emitting Color: RGB
- Viewing Angle :120°

CUSTOMER APPROVED SIGNATURES	APPROVED BY	CHECKED BY	PREPARED BY

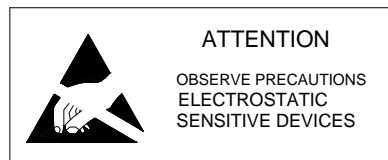

---

**Description:**

## WS2812B

### Point Control Integrated LED Light Source

---

5mm WS2812B straw hat LED is a light emitting diode with integrated digital control circuit in shape of 5mm Straw hat. Each lighting element is a pixel. The intensities of the pixels are contained within the intelligent digital interface input. The output is driven by patented PWM technology, which effectively guarantees high consistency of the color of the pixels. The control circuit consists of a signal shaping amplification circuit, a built-in constant current circuit, and a high precision RC oscillator.

The data protocol being used is uni-polar NRZ communication mode. The 24-bit data are transmitted from the controller to DIN of the first element, and if it is accepted it is extracted pixel to pixel. After an internal data latch, the remaining data pass through the internal amplification circuit and send out on the DO port to the remaining pixels. The pixel is reset after the end of DIN. Using automatic shaping forwarding technology makes the number of cascaded pixels without signal transmission only limited by signal transmission speed.

The LED has a low driving voltage (which allows for environmental protection and energy saving), high brightness, scattering angle, good consistency, low power, and long life. The control circuit is integrated in the LED above.

#### Main Application Field:

- Full color LED string light, LED full color module, LED guardrail tube, LED appearance / scene lighting, spot light for advertising
- LED point light, LED pixel screen, LED shaped screen, a variety of electronic products, electrical equipment etc..

#### Description:

- LED internal integrated high quality external control line serial cascade constant current IC;
- control circuit and the RGB chip in Lamps LED components, to form a complete control of pixel, color mixing uniformity and consistency;
- built-in data shaping circuit, a pixel signal is received after wave shaping and output waveform distortion will not guarantee a line;
- The built-in power on reset and reset circuit, the power does not work;
- gray level adjusting circuit (256 level gray scale adjustable);
- red drive special treatment, color balance;
- line data transmission;
- plastic forward strengthening technology, the transmission distance over 10m;
- Using a typical data transmission frequency of 800 Kbps with refreshing rate of 30 frames/sec.

#### Mechanical

# WS2812B

## Point Control Integrated LED Light Source

### Dimension:

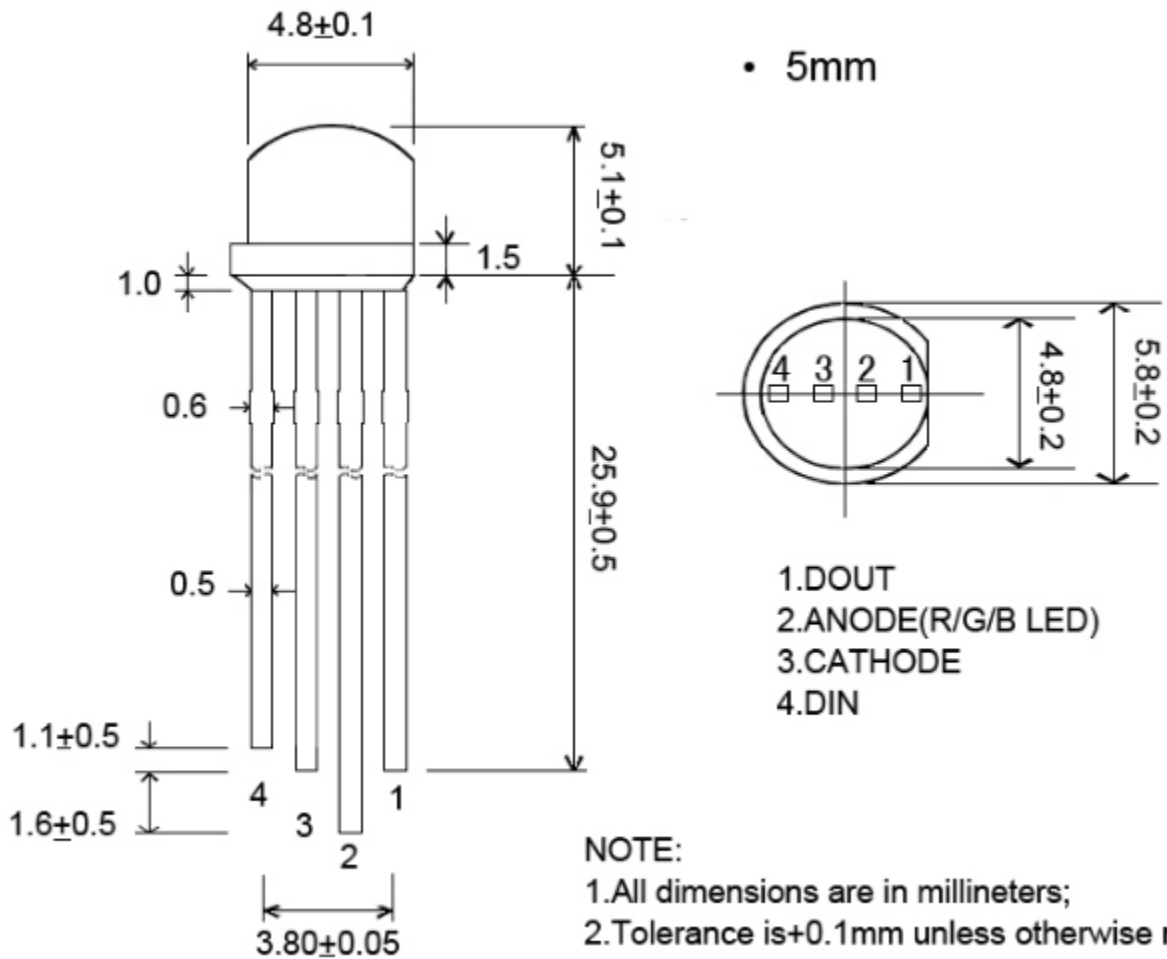

NO.	Symbol	Function description
1.	DOUT	Control data signal output
2.	VDD	Power supply LED
3.	VSS	Ground
4.	DIN	Control data signal input

### Absolute Maximum Ratings (Ta=25°C, VSS=0V)

Parameter	Symbol	Range	Unit
Power supply voltage	VDD	+3.5~+5.5	V
Logic input voltage	VIN	-0.5~VDD+0.5	V
Working temperature	Topt	-40~+85	°C
Storage temperature	Tstg	-50~+150	°C
ESD pressure	VESD	4K	V

### Electrical/Optical Characteristics (TA=25°C, VDD=5.0V, VSS=0V)

## WS2812B

### Point Control Integrated LED Light Source

#### RED COLOR:

Parameter	Symbol	Min	Typ.	Max	Unit	Test Condition
Forward voltage	$V_F$	1.8	2.0	2.2	V	$I_F=20\text{ mA}$
Luminous intensity	$I_V$	1000	1250	1500	mcd	$I_F=20\text{ mA}$
Peak emission wavelength	$\lambda_p$	620	622.5	625	nm	❖
Half intensity angle	$2\theta_{1/2}$	❖	120	❖	deg	❖

#### GREEN COLOR:

Parameter	Symbol	Min	Typ.	Max	Unit	Test Condition
Forward voltage	$V_F$	3.0	3.2	3.4	V	$I_F=20\text{ mA}$
Luminous intensity	$I_V$	1500	1850	2200	mcd	$I_F=20\text{ mA}$
Peak emission wavelength	$\lambda_p$	520	522.5	525	nm	❖
Half intensity angle	$2\theta_{1/2}$	❖	120	❖	deg	❖

#### BLUE COLOR:

Parameter	Symbol	Min	Typ.	Max	Unit	Test Condition
Forward voltage	$V_F$	3.0	3.2	3.4	V	$I_F=20\text{ mA}$
Luminous intensity	$I_V$	700	850	1000	mcd	$I_F=20\text{ mA}$
Peak emission wavelength	$\lambda_p$	465	467.5	470	nm	❖
Half intensity angle	$2\theta_{1/2}$	❖	120	❖	deg	❖

Parameter	Symbol	Min	Typical	Max	Unit	Test
The chip supply voltage	VDD	---	5.2	---	V	
R/G/B port pressure	VDS, MAX	---	---	26	V	
DOUT drive capability	IDOH	---	49	---	mA	DOUT conect ground, the maximum drive current
	IDOL	---	-50	---	mA	DOUT conect +, the largest current
The signal input flip threshold	VIH	3.4	---	---	V	VDD=5.0V
	VIL			1.6	V	
The frequency of PWM	FPWM	---	1.2	---	KHZ	
Static power consumption	IDD	---	1	---	mA	

#### Dynamic Parameters (Ta=25°C):

## WS2812B

### Point Control Integrated LED Light Source

Parameter	Symbol	Min	Typical	Max	Unit	Test
The speed of data transmission	fDIN	---	800	---	KHZ	The duty ratio of 67% (data 1)
DOUT transmission delay	TPLH	---	----	500	ns	DIN→DOUT
	TPHL	---	---	500	ns	
IOUT Rise/Drop Time	Tr		100		ns	VDS=1.5 IOUT=13mA

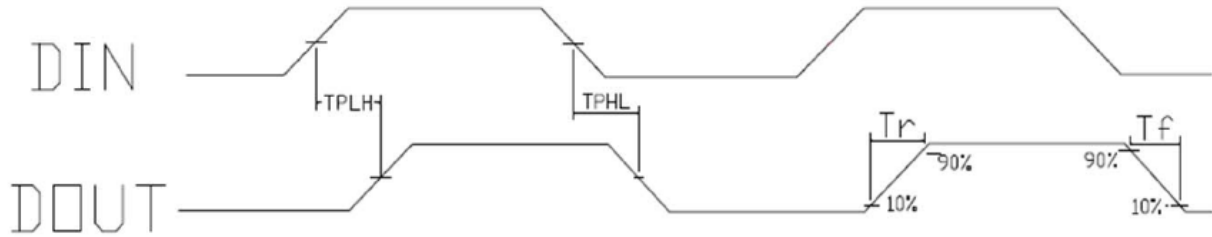

#### The Data Transmission Time ( $T_H+T_L=1.25 \mu s \pm 600ns$ ):

TOH	0 code, high level time	0.3 $\mu s$	$\pm 0.15\mu s$
TOL	0 code, low level time	0.9 $\mu s$	$\pm 0.15\mu s$
T1H	1 code, high level time	0.6 $\mu s$	$\pm 0.15\mu s$
T1L	1 code, low level time	0.6 $\mu s$	$\pm 0.15\mu s$
Trst	Reset code, low level time	80 $\mu s$	

#### Timing waveform:

#### Input code:

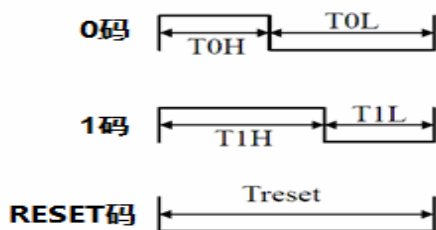

#### Connction mode:

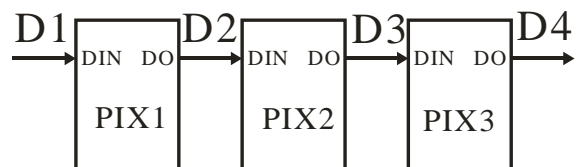

**The method of data transmission:**

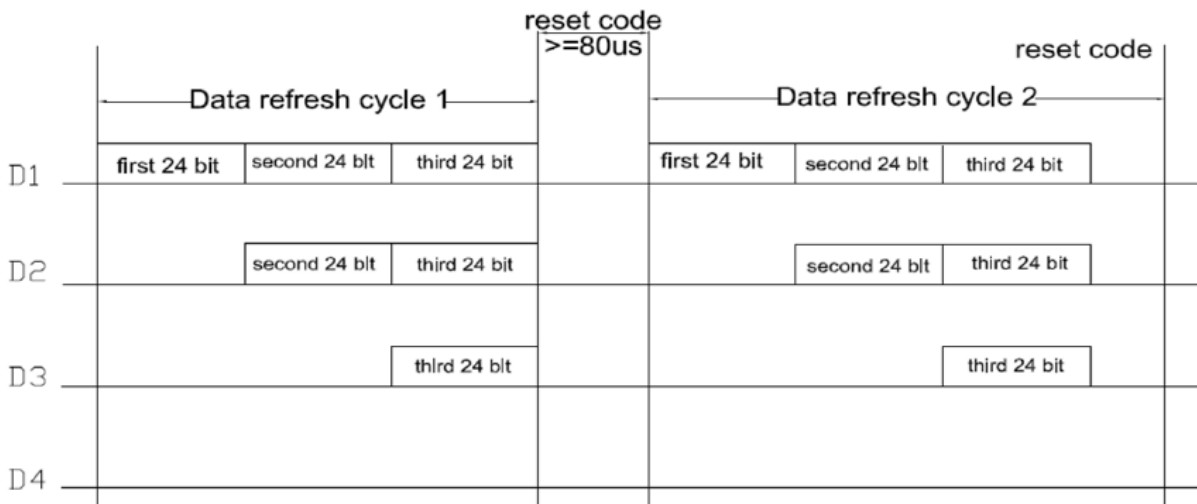

Note: the D1 sends data for MCU, D2, D3, D4 for data forwarding automatic shaping cascade circuit.

**The data structure of 24bit:**

G7	G6	G5	G4	G3	G2	G1	G0	R7	R6	R5	R4	R3	R2	R1	R0	B7	B6	B5	B4	B3	B2	B1	B0
----	----	----	----	----	----	----	----	----	----	----	----	----	----	----	----	----	----	----	----	----	----	----	----

Note: high starting, in order to send data (G7 - G6 - ..... ..B0)

# WS2812B

## Point Control Integrated LED Light Source

The typical application circuit:

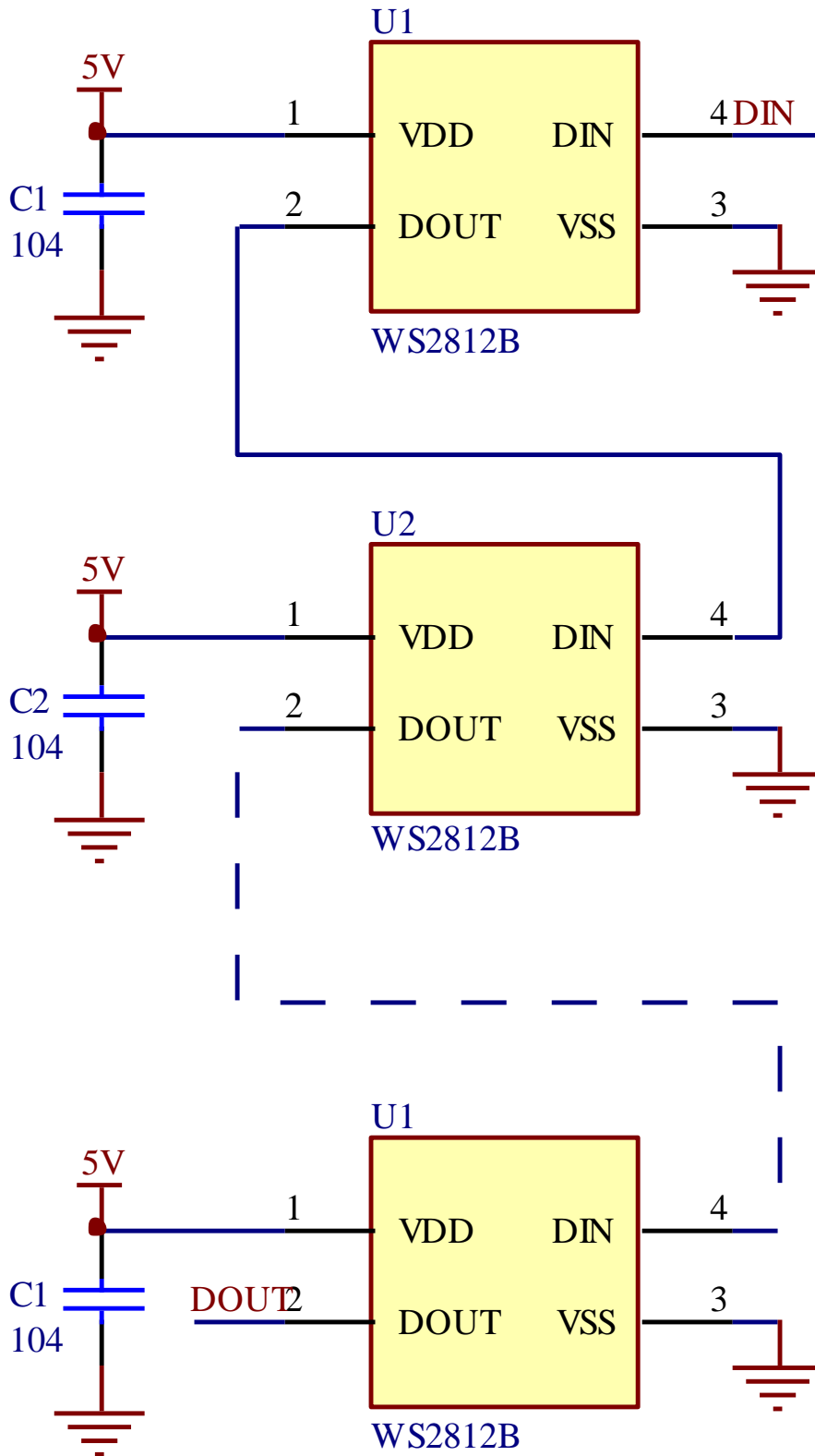

Standard LED Performance Graph:

Typical Relative Luminous Flux vs. Forward Current

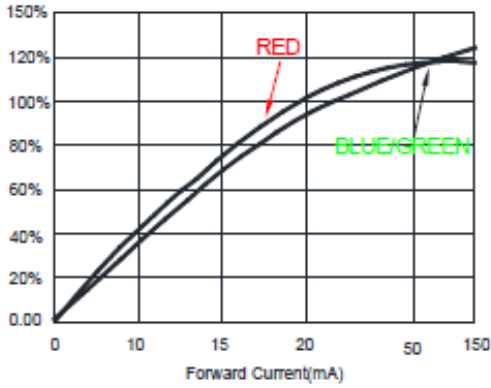

Forward Voltage vs. Forward Current

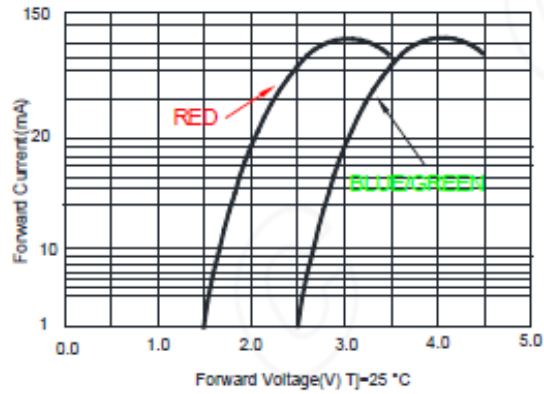

Thermal Pad Temperature vs. Relative Light Output

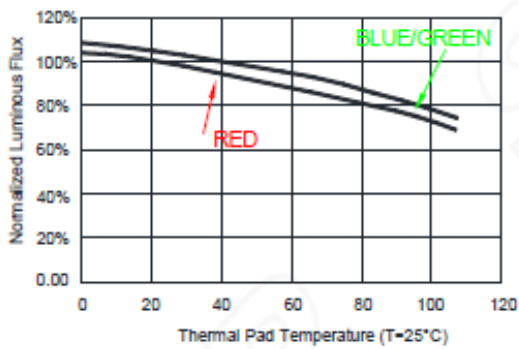

Wavelength Characteristics

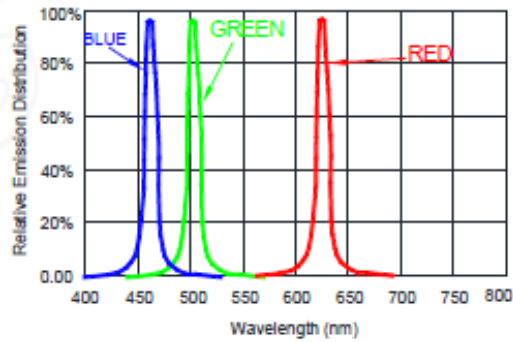

Thermal Pad Temperature vs. Forward Current

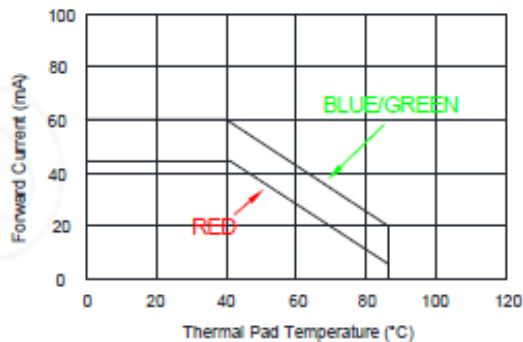

Typical Radiation Pattern 120°

